

Orderpicken binnen non-food E-commerce



GROENEWOUT



Dinsdag 11 juni 2013 Hotel Houten
logistiek &
e-commerce



Paul Haagh

9026X090/PH/ld v2.0

Introductie

Supply Chains Management



Onafhankelijk

Objectief

Warehouse Logistics



Multi-disciplinair

Kennis

Construction Mgt. & Engineering



Calculatie

Pragmatisch

Introductie

(Fine) Chemicals



Healthcare



Electronics



3rd-Party Logistics Service Providers



Fast Moving Consumer Goods



And many other industries



Introductie

On-line verkopen in NL €10 miljard

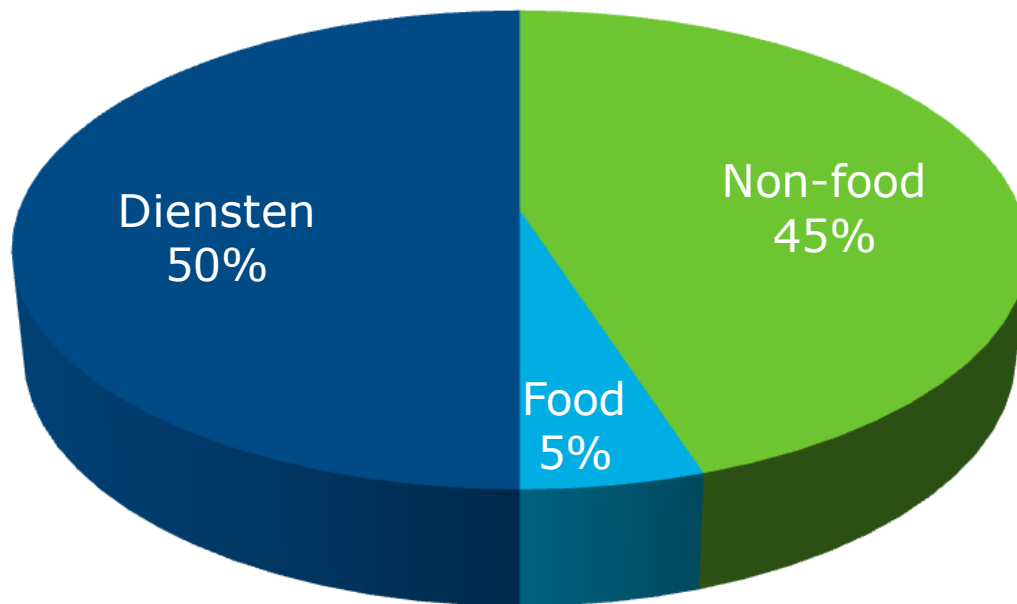

Non-food on-line:

€4.5 miljard omzet in 2012

400.000 pakketjes per dag

Groei 10% per jaar

Traditionele B2B warehouse processen

GEVOLGEN E-COM

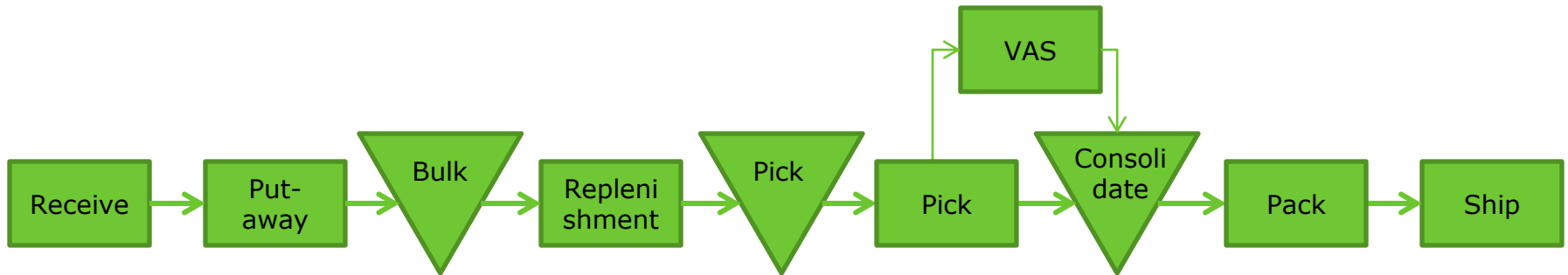

Picken op klantniveau

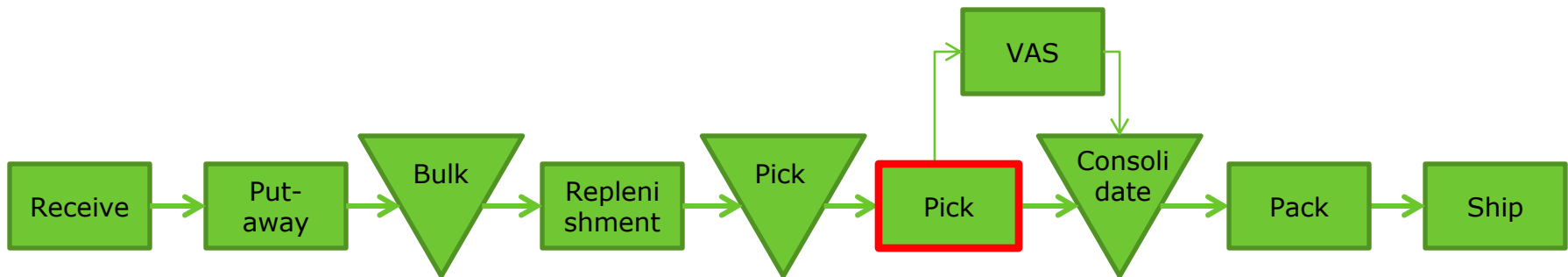

- Fijner picken: besteleenheid → consumenteneenheid
- Meer klanten per dag: 100 winkels → 10.000 consumenten
- Kleinere orders: 100 regels per order → 1-2 regels per order
- Kortere doorlooptijd: dag → enkele uren

Retouren

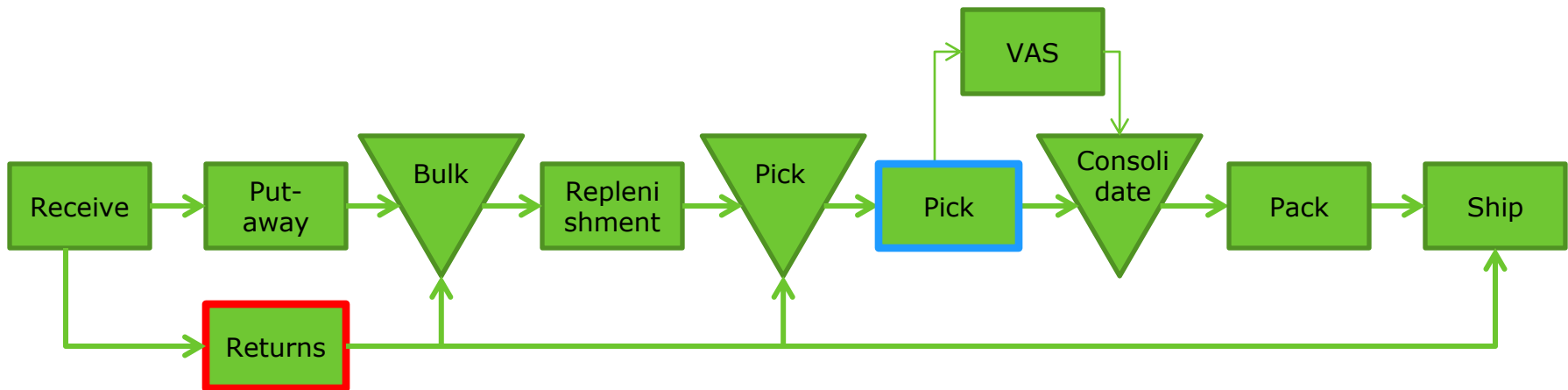

- B2B retouren naar winkels → E-com retouren naar warehouse
- Grote verschillen in retourstromen: kleding 30%-70%, electronica 1%-5%
- FIFO: samenvoegen op picklocatie

Voorraad op meerdere plaatsen in de keten

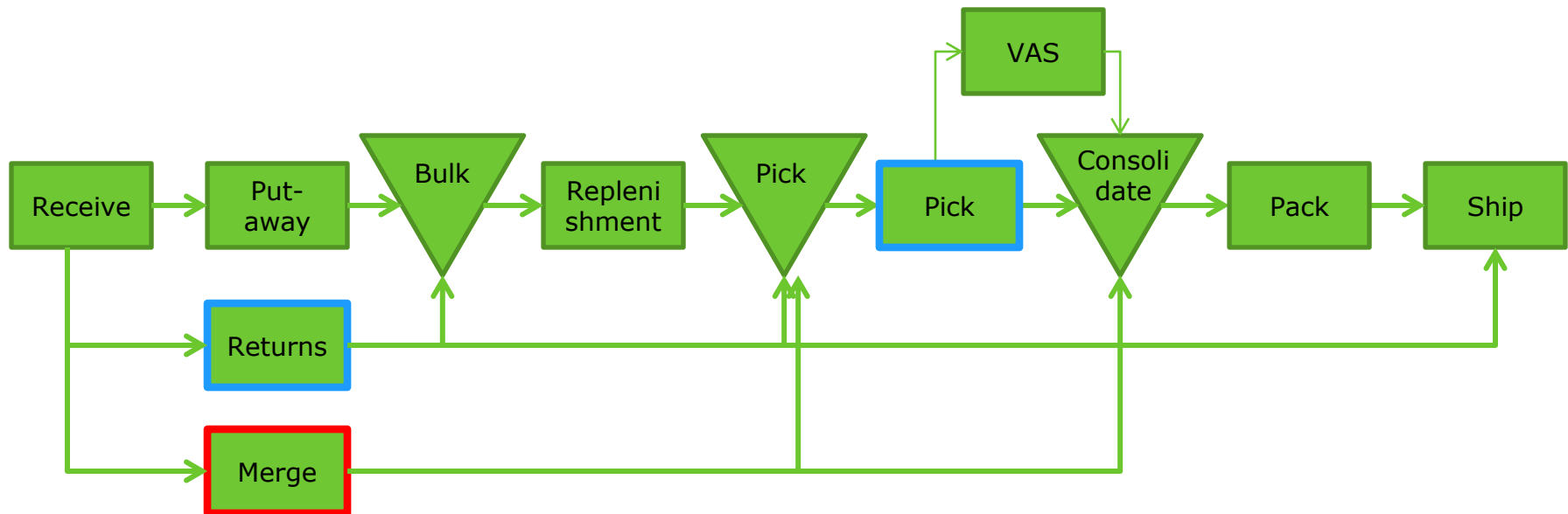

- Long tail logistiek: langzaamlopende artikelen stroomopwaarts in de keten
- Samenwerking tussen lokale partijen om levertijd te verkorten
- Klant wil graag één pakketje ontvangen

Klantspecifieke producten

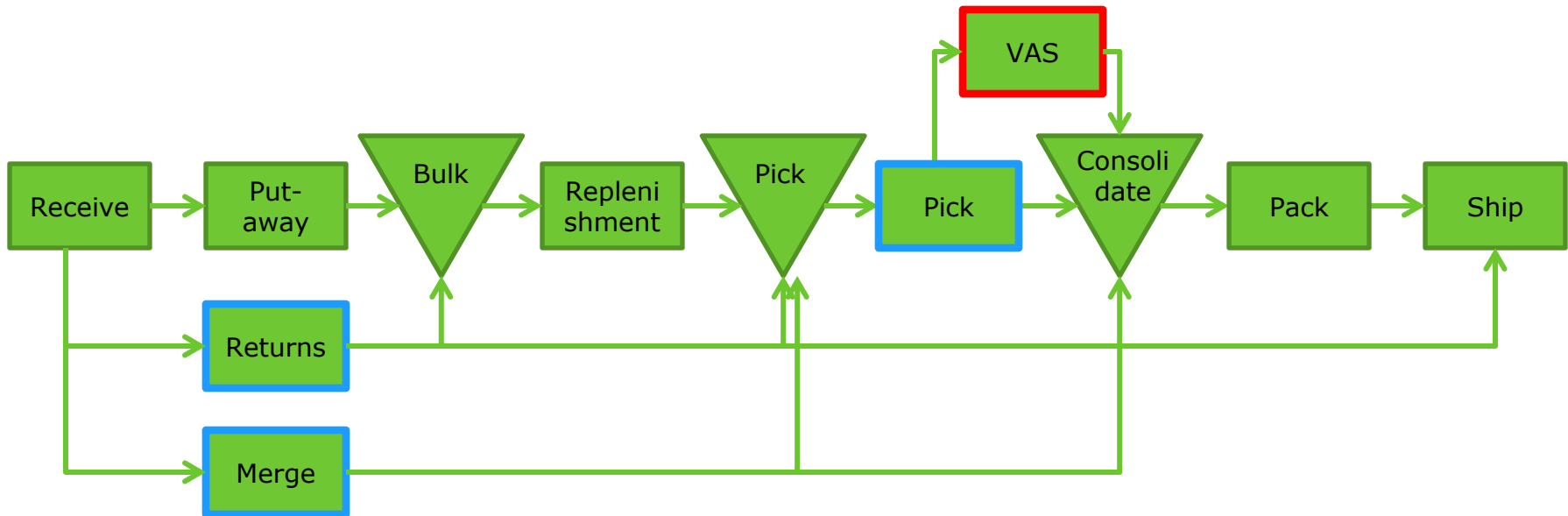

- Klant wil producten zelf kunnen samenstellen
- Marketing: specifieke verpakkingen

Versturen naar consumenten

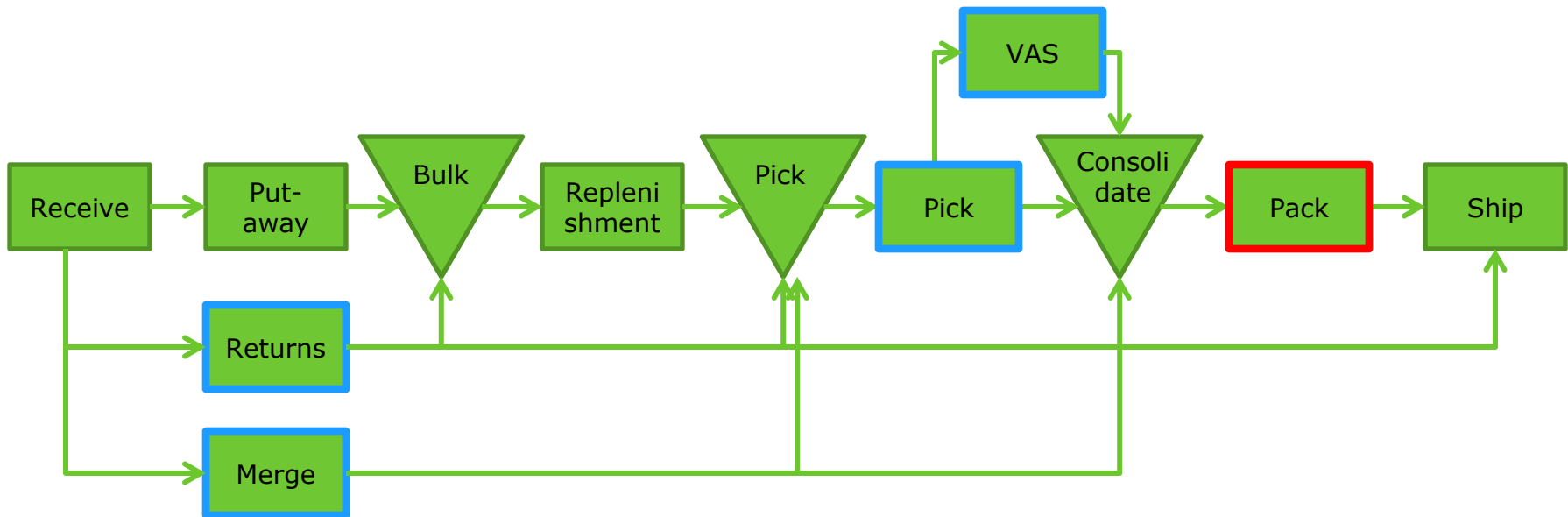

➤ B2B op pallet/rolcontainer/bak → E-com in verzenddoos

FTE verdeling

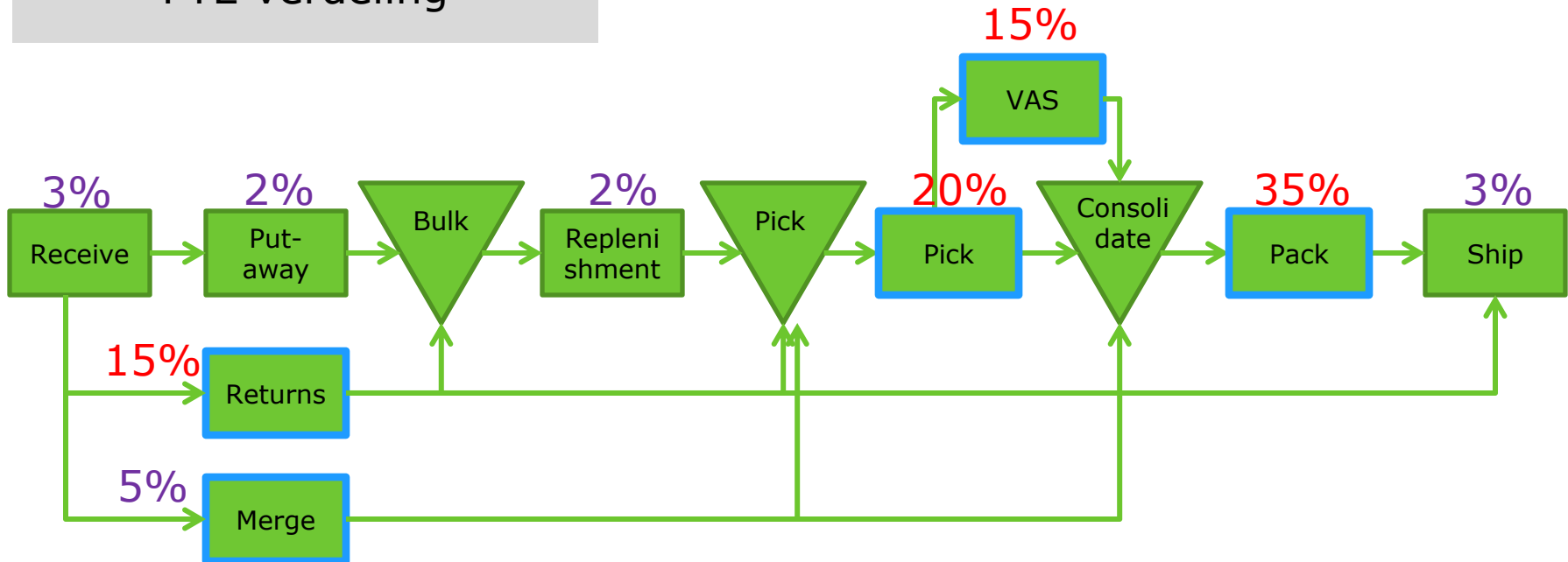

- Besparingen zoeken in Pick, Pack, VAS, Returns
- Pickoplossingen zijn al ver ontwikkeld
- Komende jaren veel ontwikkelingen op Pack en Returns

Vragen

Non-food E-commerce:

A. Wat zijn de factoren die je in beschouwing moet nemen bij de bepaling van het orderpickproces?

B. Wanneer pas ik welke orderpickoplossing toe?

Factoren:

- Orderprofiel
- Orderpickstrategie
- ABC patroon
- Groei scenario: volume en assortiment
- Mechanisatie: artikelgrootte

Non-food E-commerce:

- Veel kleine orders met weinig regels en weinig stuks

orderprofiel	totaal	1 stuks orders	overige orders
verdeling	100%	30%	70%
gem #regels per order	1.9	1	2.2
gem #stuks per regel	1.1	1	1.2
gem #stuks per order	2.0	1	2.5

Pick per order

Pick en sorteer naar
klantorders tijdens
orderpicken

Karakteristieken

- Korte doorlooptijd
- Bij kleine orders al gauw veel lopen
- 1 stuks orders in één route

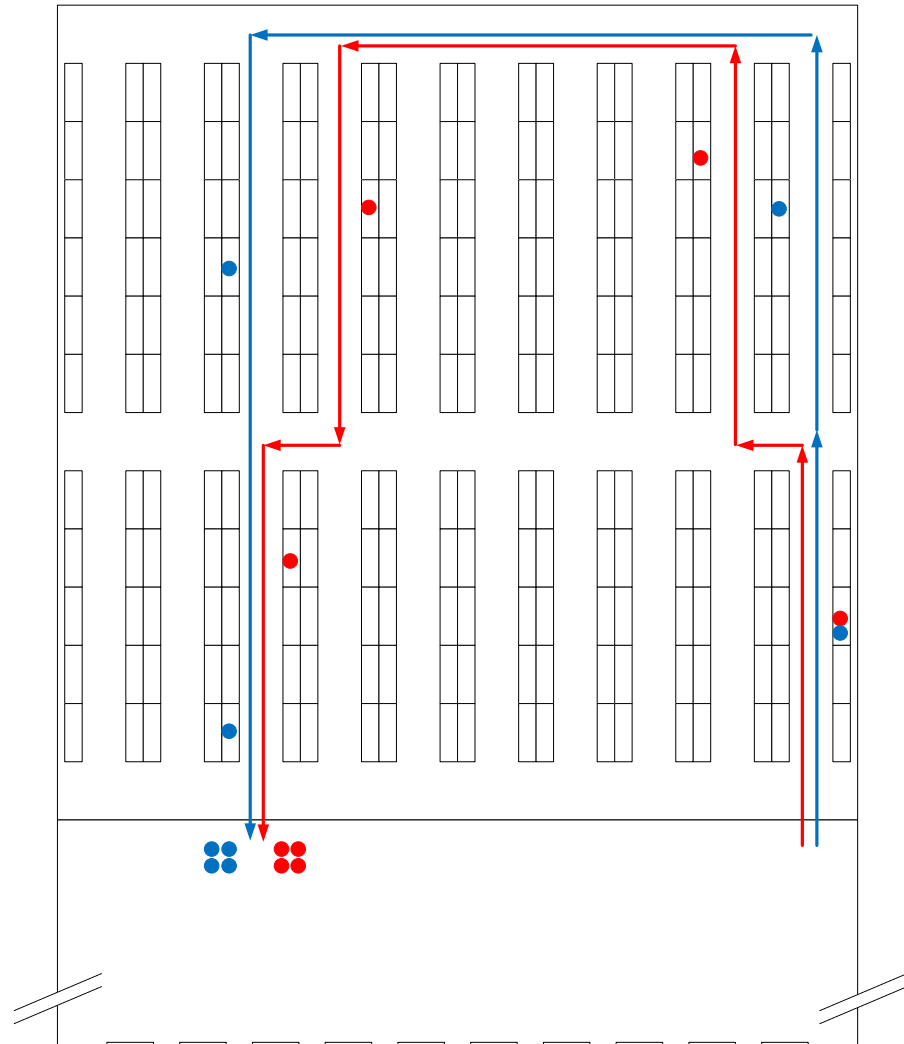

Pick per batch

Pick alle artikelen
voor een set (batch)
van klantorders

Sorteer naar
klantorders

Karakteristieken

- Efficiënt picken
- Langere doorlooptijd
- Veel sorteerrichtingen nodig

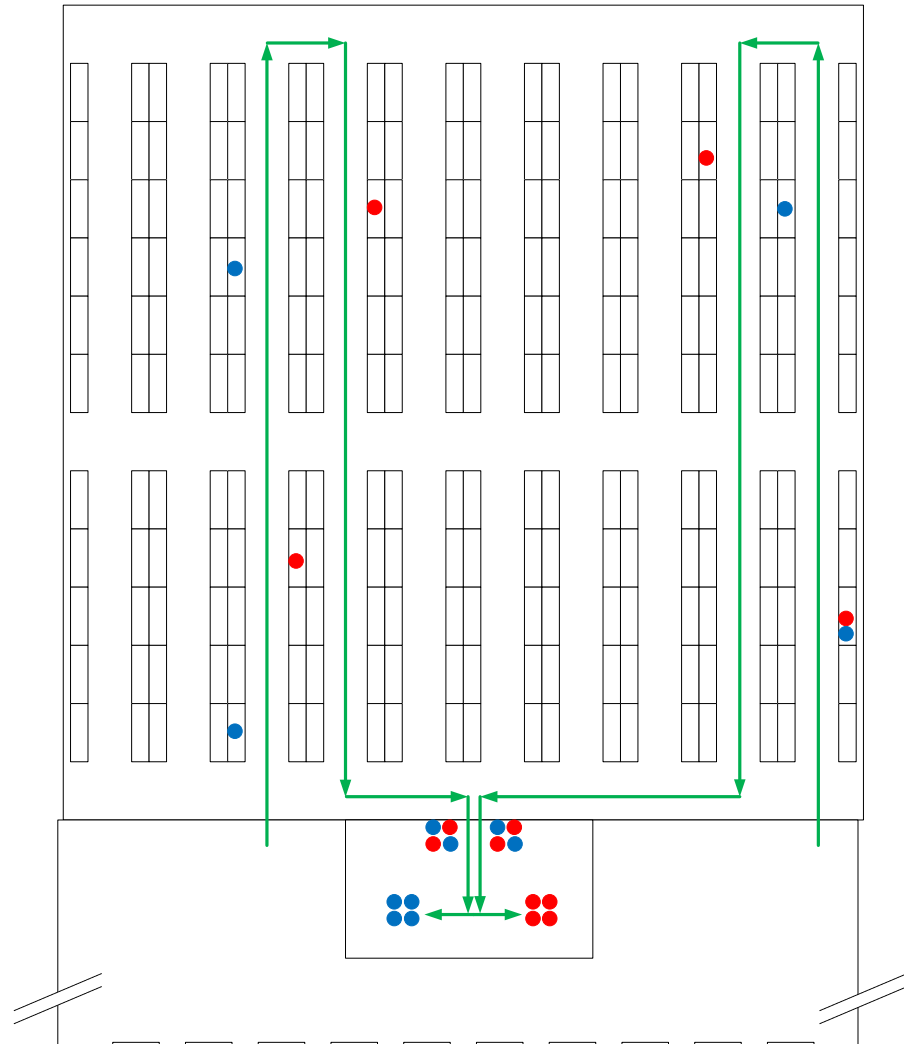

ABC patroon

Traditioneel B2B patroon:

- 80/20 regel
- Heldere splitsing snel- en langzaamlopers

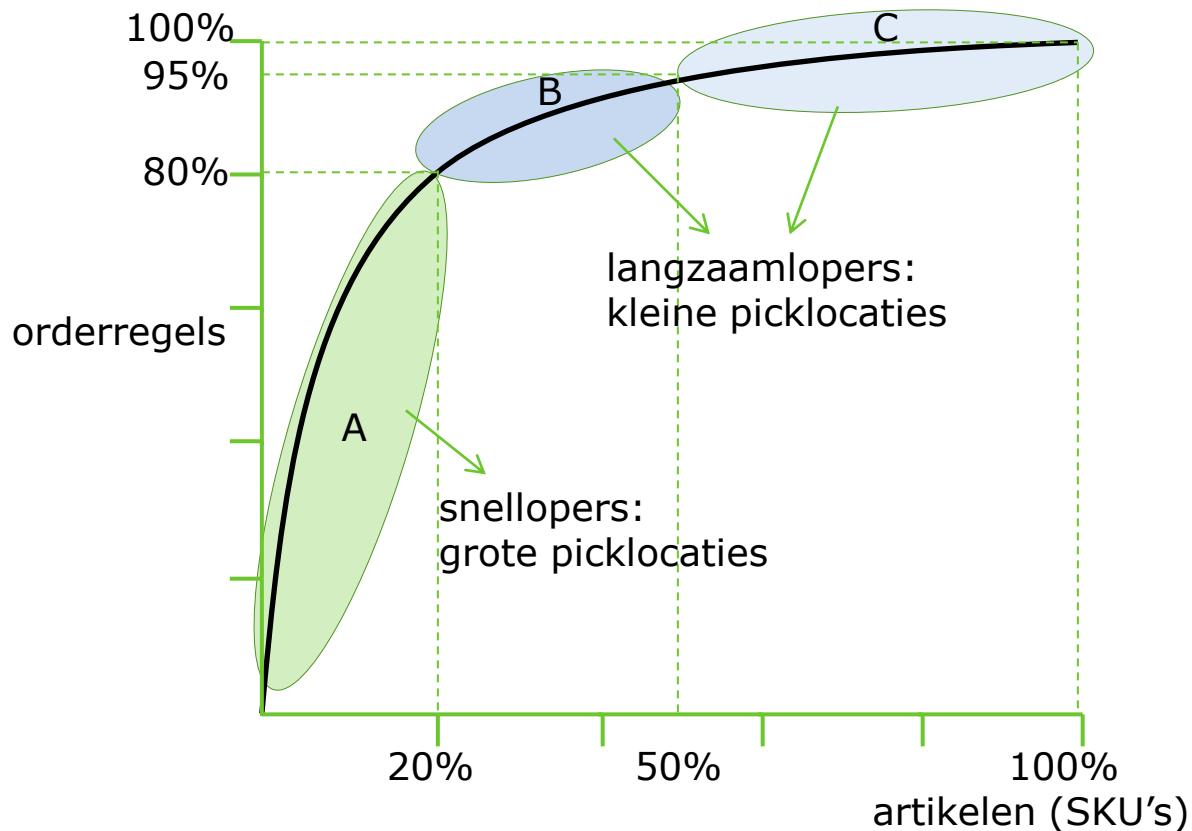

E-com:

- minder echte A-artikelen (snellopers)
- snelle wisselingen tussen A artikelen en B/C artikelen

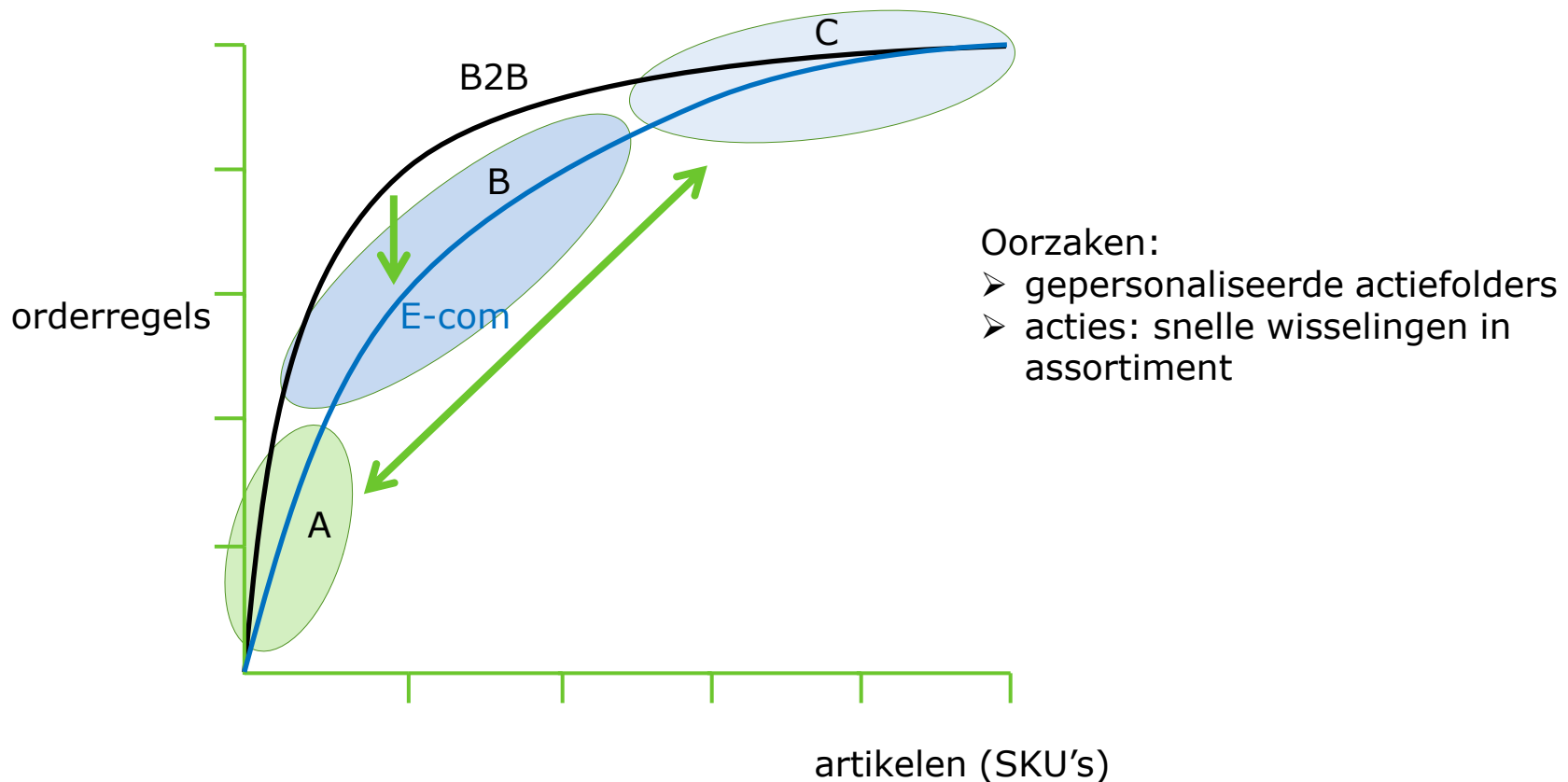

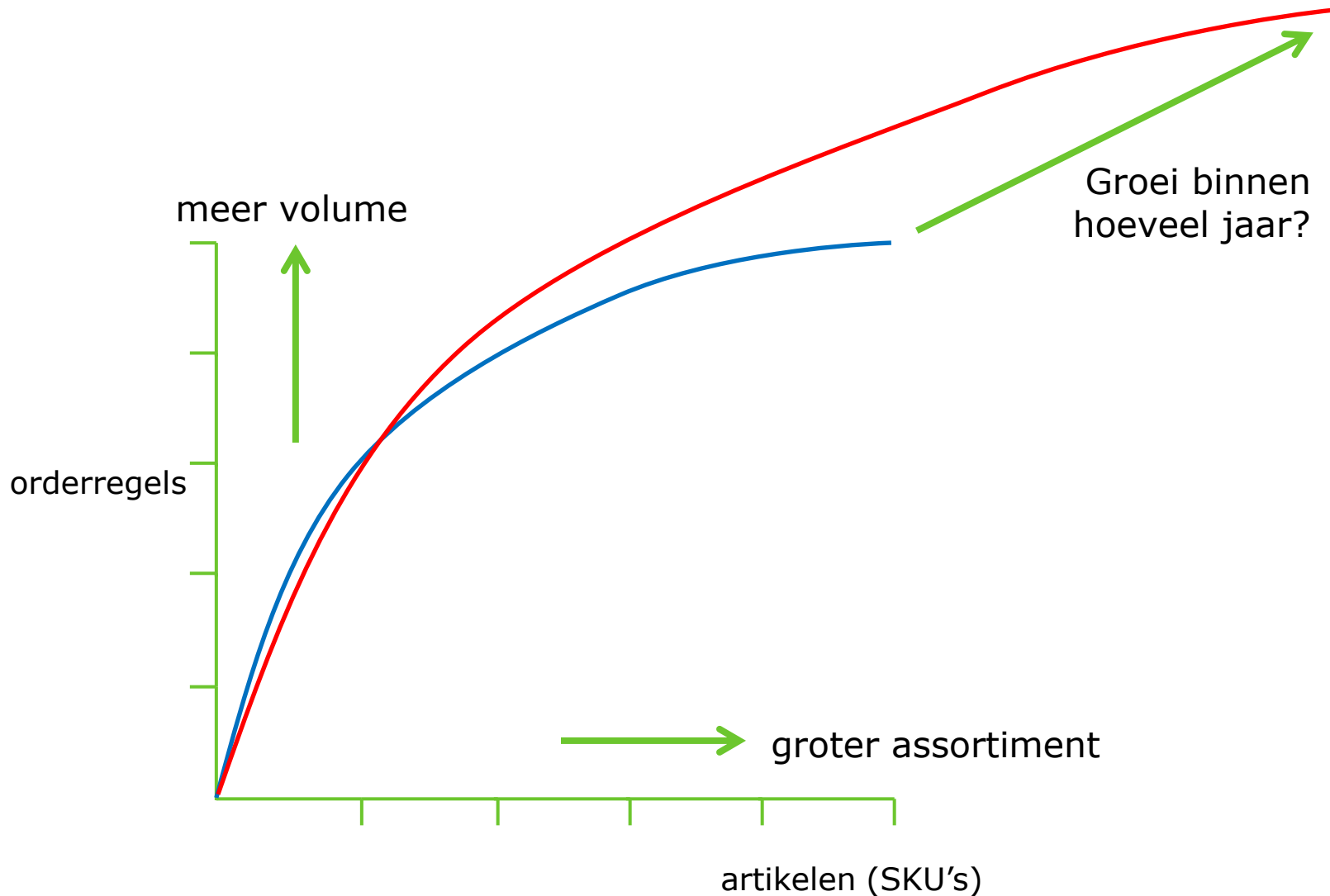

Mechanisatie? → Artikelgrootte

FACTOREN

Welke artikelen zijn geschikt voor gemechaniseerde oplossingen?



bak



omdoos



ugly



pallet

Welke oplossing?

FACTOREN

Bekijk afzonderlijk:

A. Langzaamlopers / snellopers

B. Artikelgrootte

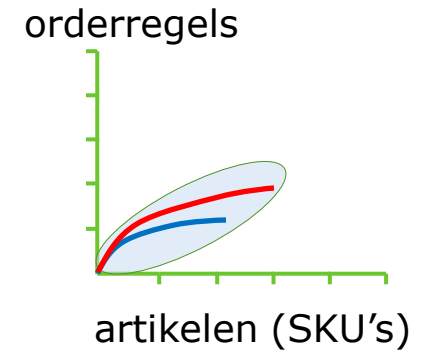
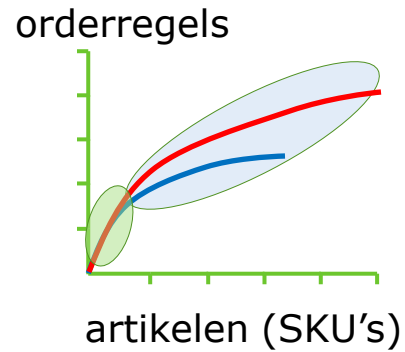
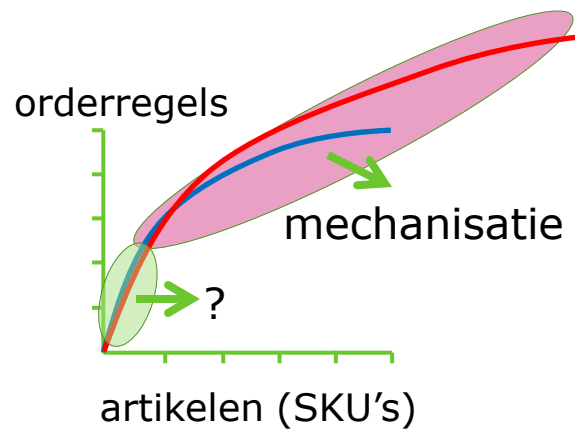

Vragen

Non-food E-commerce:

A. Wat zijn de factoren die je in beschouwing moet nemen bij de bepaling van het orderpickproces?

B. Wanneer pas ik welke orderpickoplossing toe?

B. Orderpickoplossingen

Strategie

- Pick per order
- Pick per batch

Conventioneel orderpicken

OPLOSSING - PICK PER ORDER

Voordeel:

- toepasbaar op alle artikelen
- geringe investering

Beperking:

- lange loopafstanden
- congestie

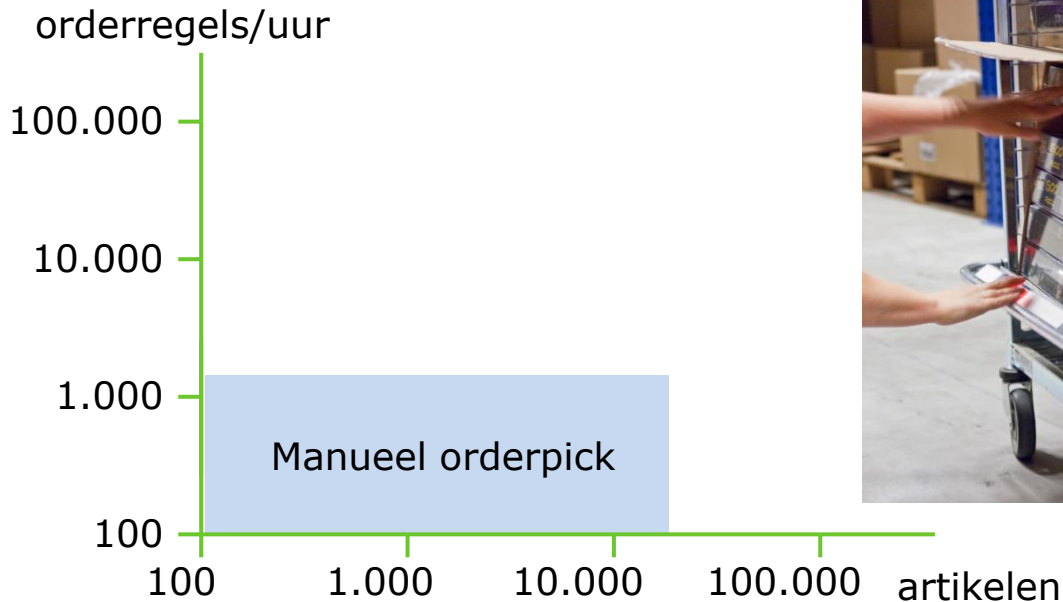
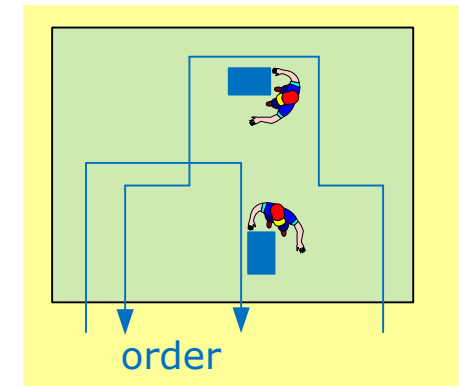

INOTHER

Zone pick

OPLOSSING - PICK PER ORDER

Voordeel:

- Reductie loopafstanden/congestie

Beperking:

- Transport van orderbakken max 1.500 bakken/uur

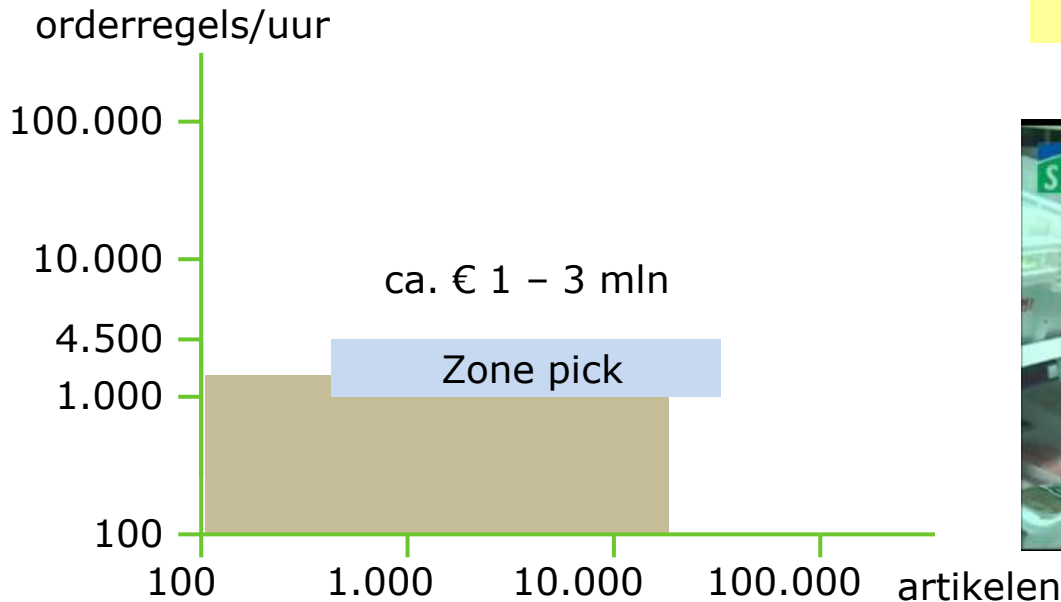
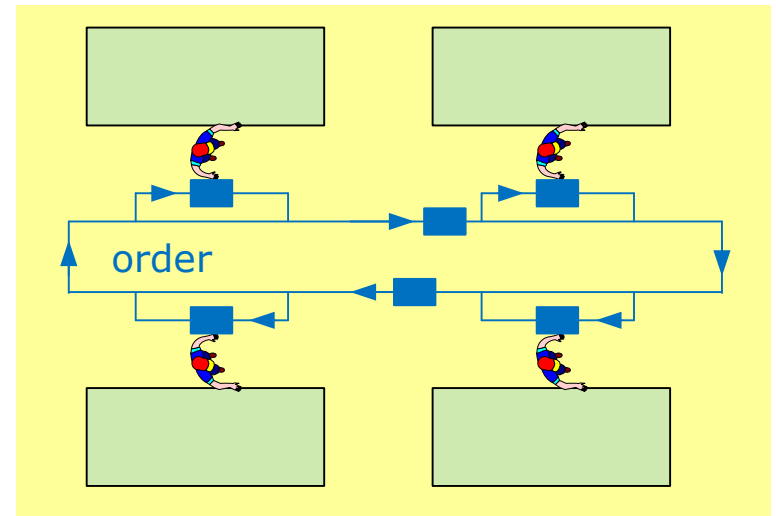

Goods-to-man

OPLOSSING - PICK PER ORDER

Voordeel:

- Hoge pickproductiviteit

Beperking:

- 1.500 artikelbakken/uur per module
- Complex bij hogere capaciteiten

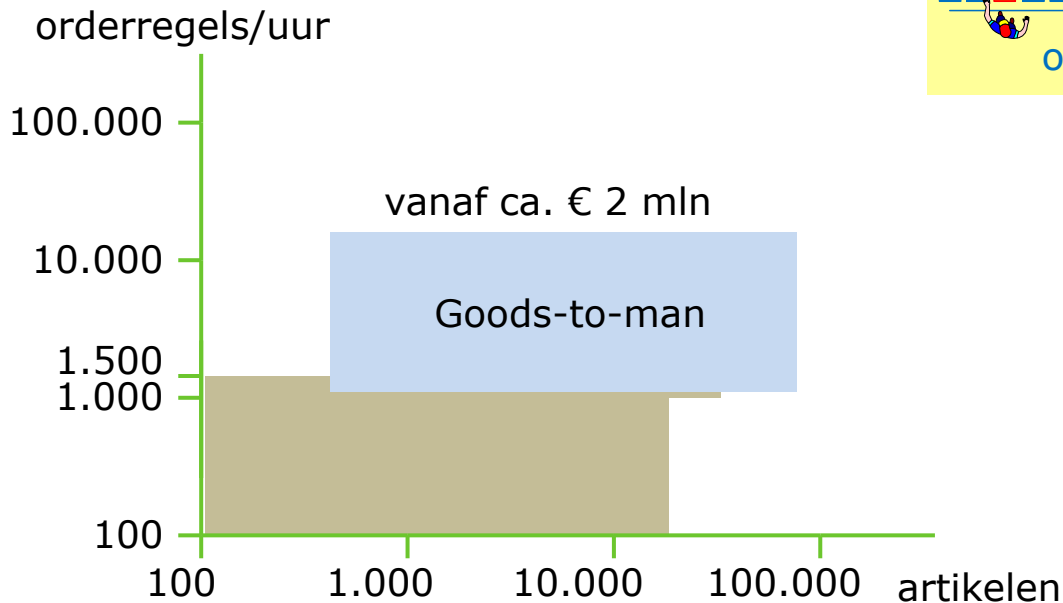
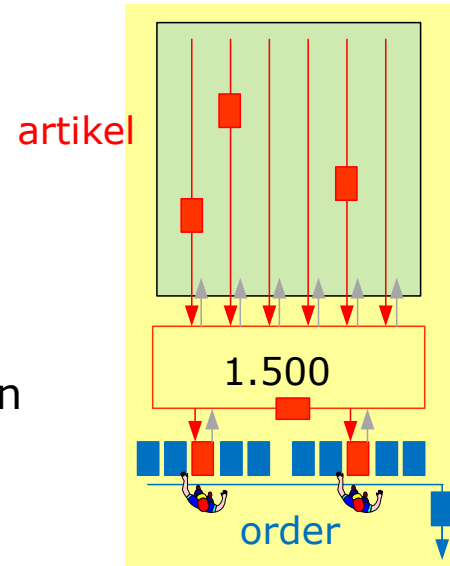

KNAPP

Goods-to-man

OPLOSSING - PICK PER ORDER

Voordeel:

- Hoge pickproductiviteit

Beperking:

- 1.500 artikelbakken/uur per module
- Complex bij hogere capaciteiten

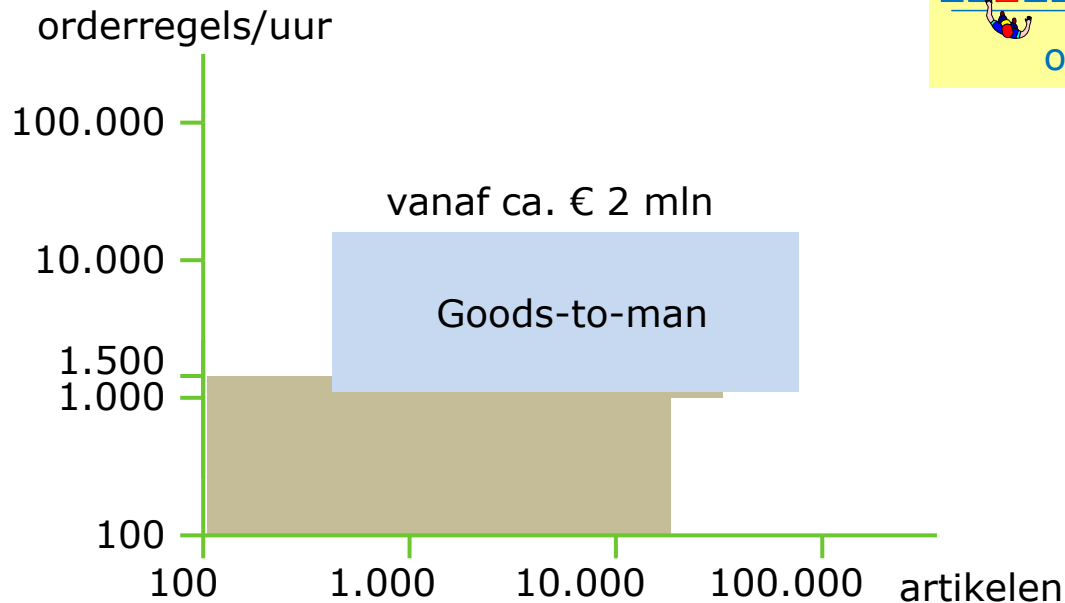
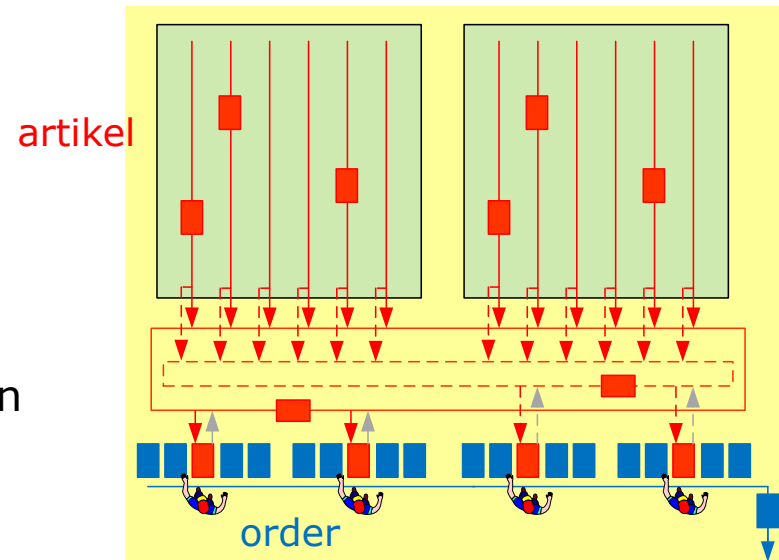

Goods-to-man

OPLOSSING - PICK PER ORDER

Voordeel:

- Hoge pickproductiviteit

Beperking:

- 1.500 artikelbakken/uur per module
- Complex bij hogere capaciteiten

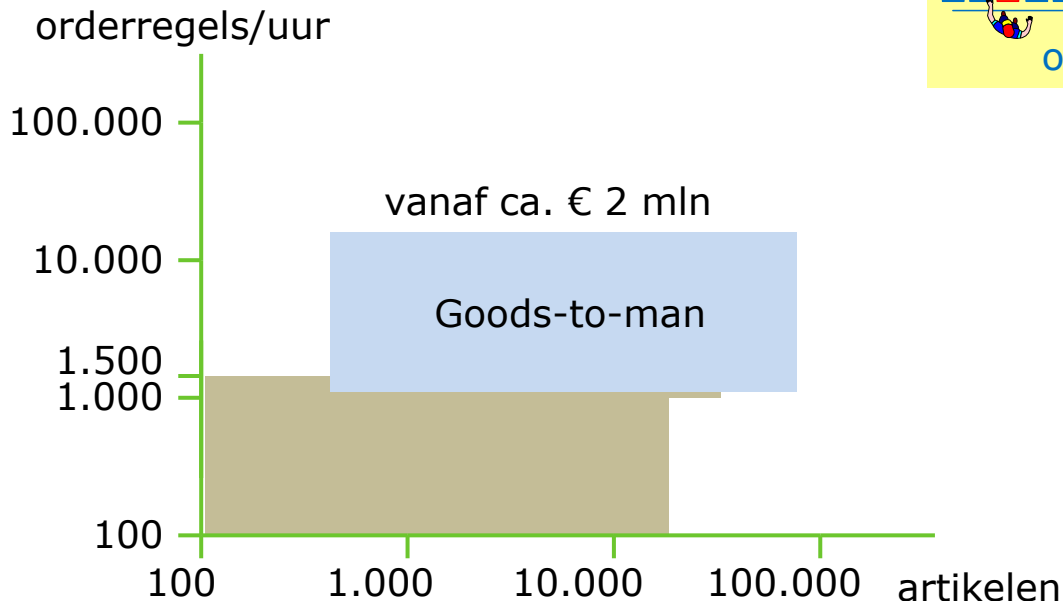
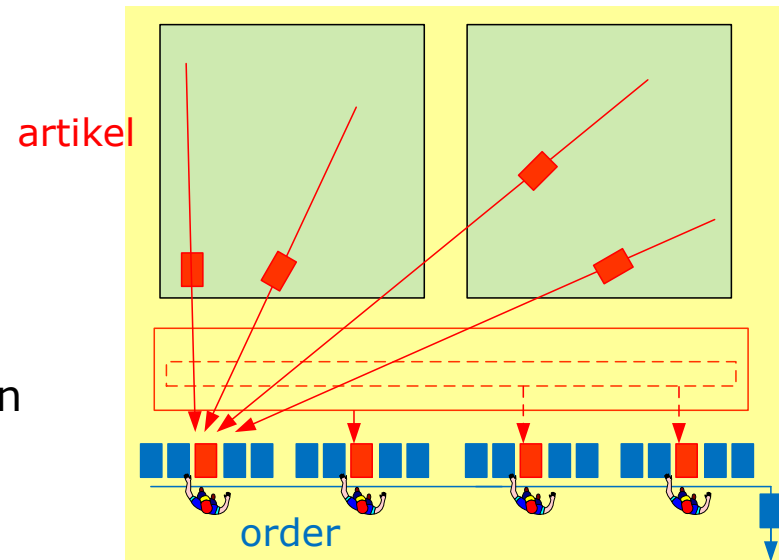

Nieuwe goods-to-man oplossingen

OPLOSSING - PICK PER ORDER

Voordeel:

- Goede schaalbaarheid
- Hoge pickproductiviteit

Beperking:

- Nieuw → nog hoge investering

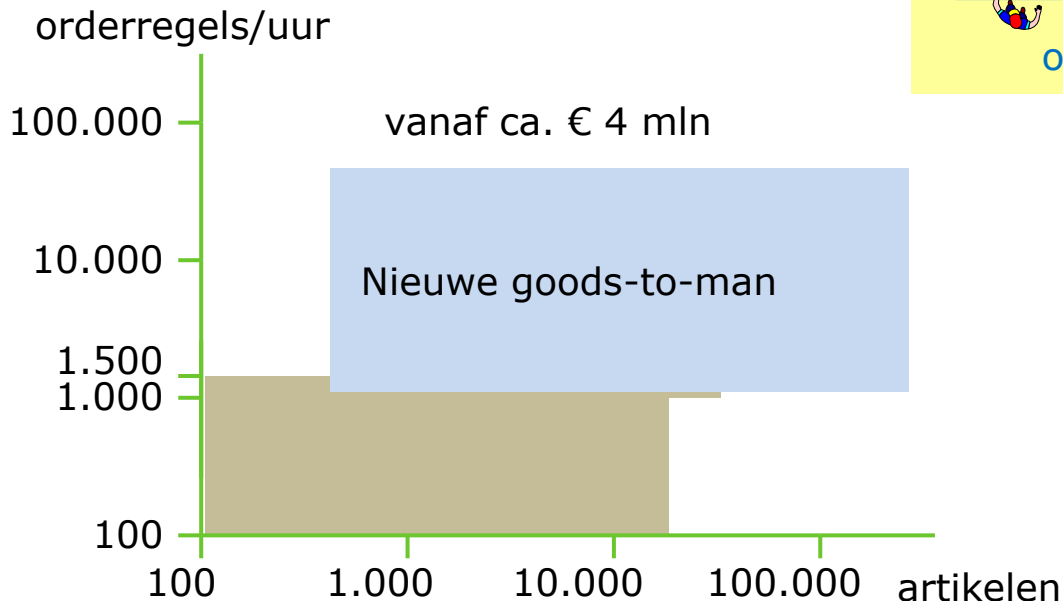
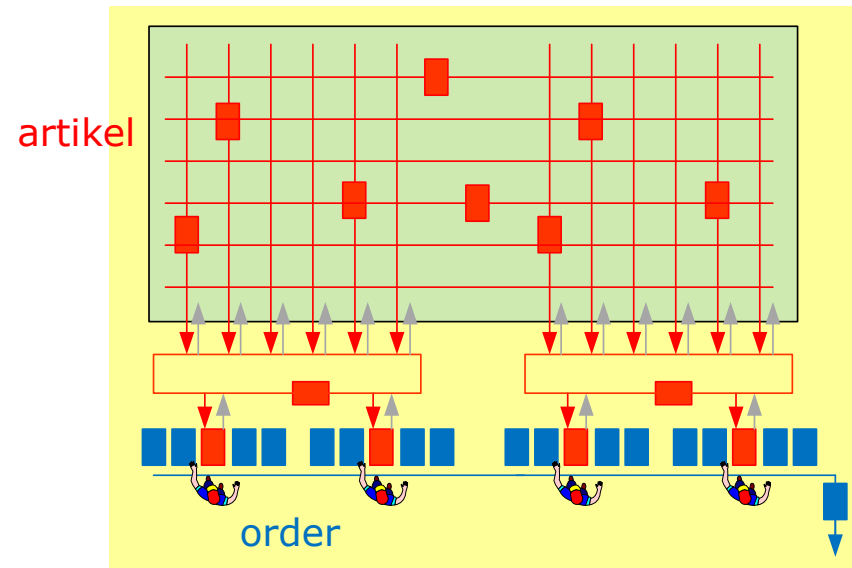

VAN DER LANDE
INDUSTRIES

Kiva (goods to man)

OPLOSSING - PICK PER ORDER

Voordeel:

- Goede schaalbaarheid
- Geen staal in gebouw

Beperking:

- Laag gebouw of vloeren
- Niet beschikbaar

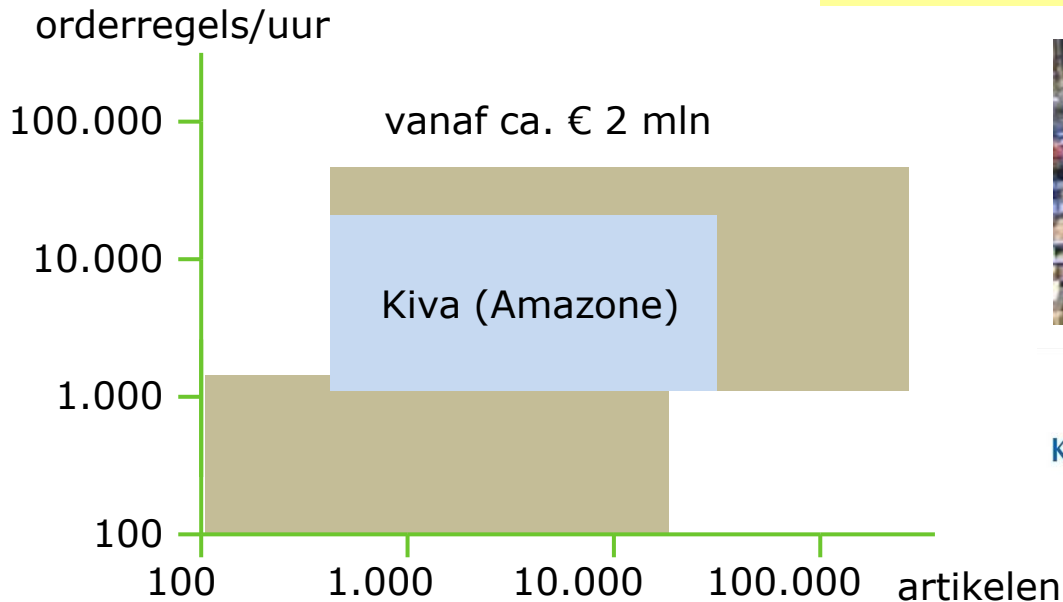
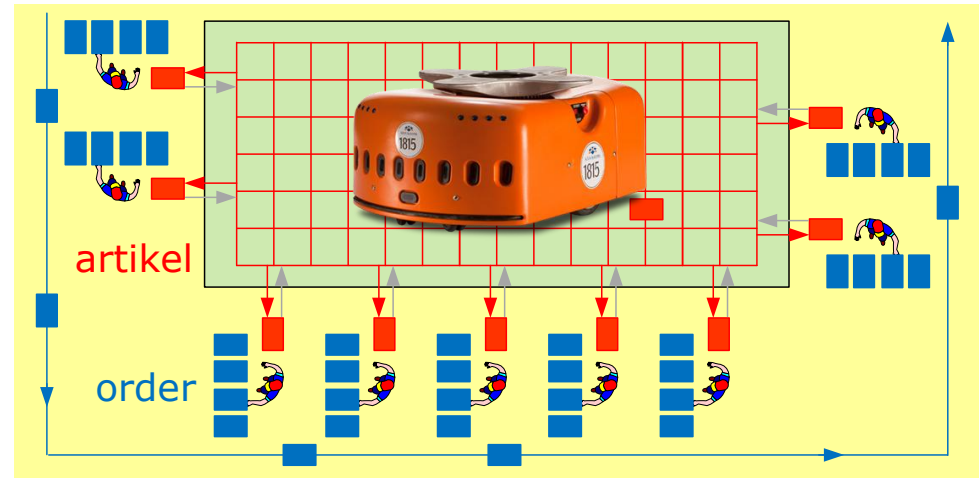

Orderpickoplossingen

Strategie

➤ Pick per order

➤ Pick per batch

Manuele batch picken

OPLOSSING - PICK PER ORDER

Voordeel:

- Efficiënt pick proces
- Geringe investering
- Schaalbaar

Beperking:

- Doorlooptijd

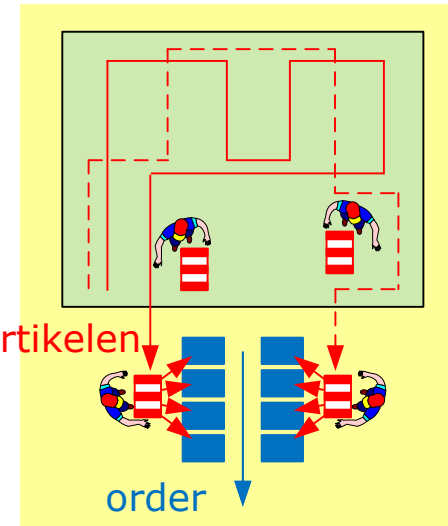

orderregels/uur

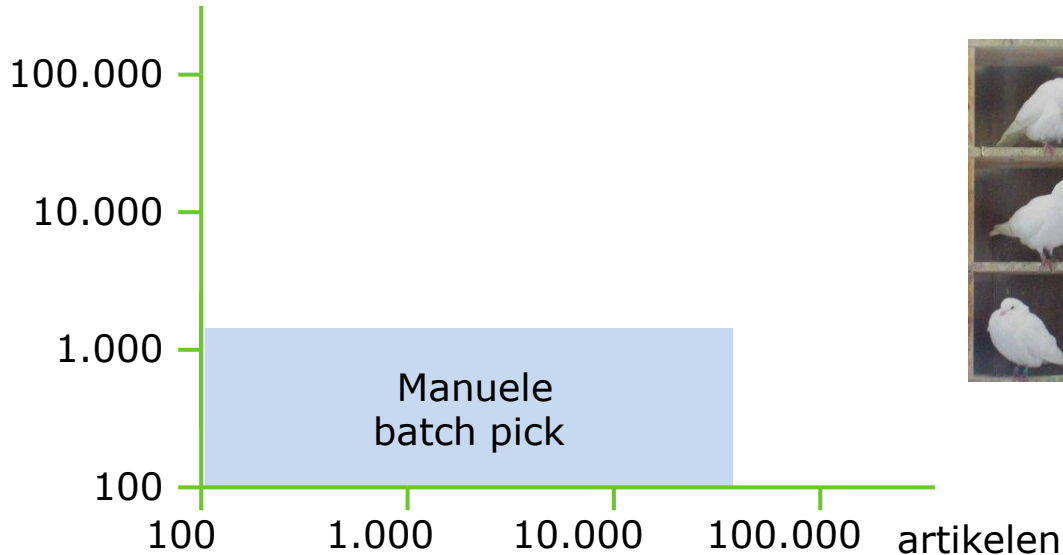

VAN DER LANDE
INDUSTRIES



Gemechaniseerde sorter

OPLOSSING - PICK PER ORDER

Voordeel:

- Efficiënt picken en sorteren zonder congestie

Beperking:

- beperkt aantal sorteeruitgangen
- grote batch: doorlooptijd 1 - 2 uren

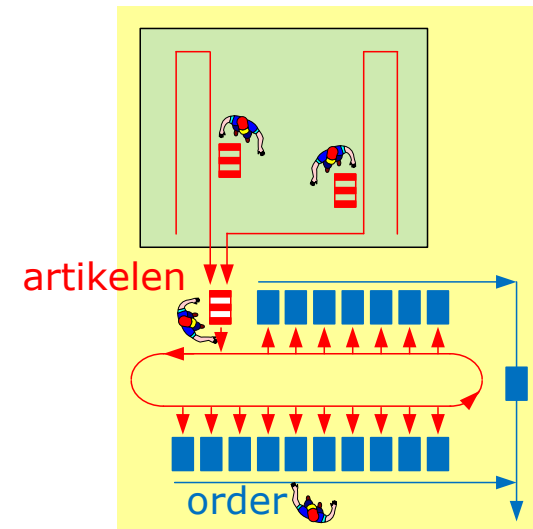

orderregels/uur

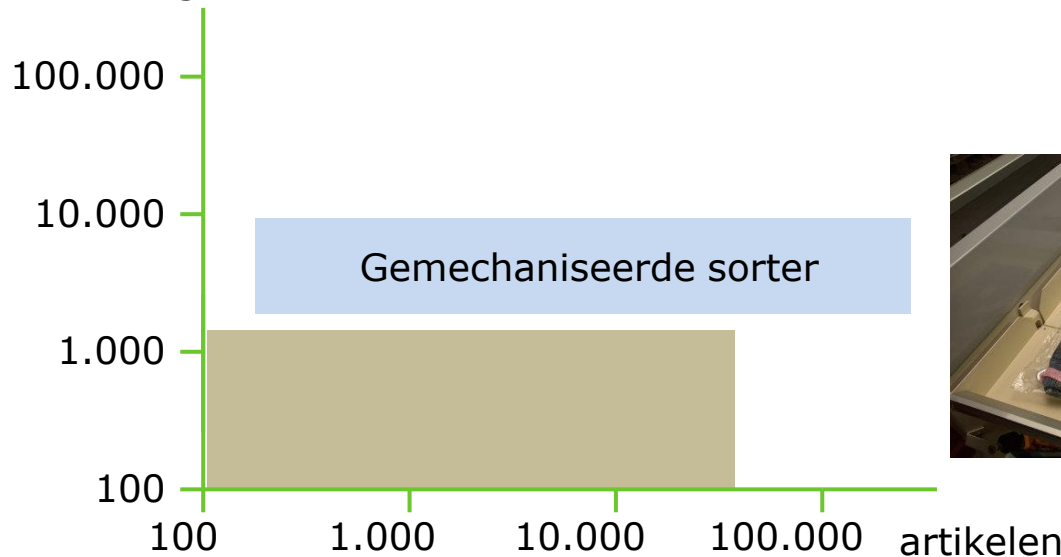

Gemechaniseerde sorter

OPLOSSING - PICK PER ORDER

Voordeel:

- Efficiënt picken en sorteren zonder congestie

Beperking:

- beperkt aantal sorteeruitgangen
- grote batch: doorlooptijd 1 - 2 uren

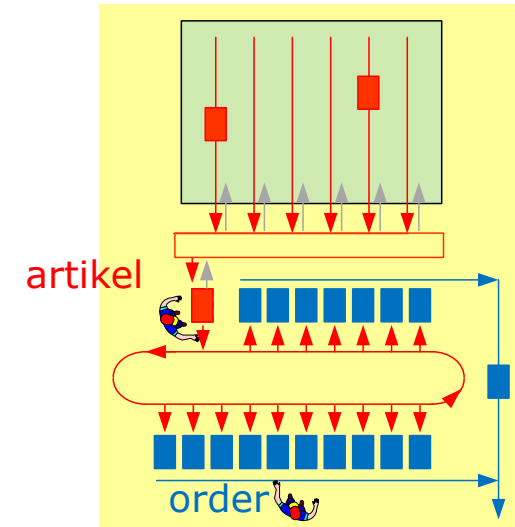

orderregels/uur

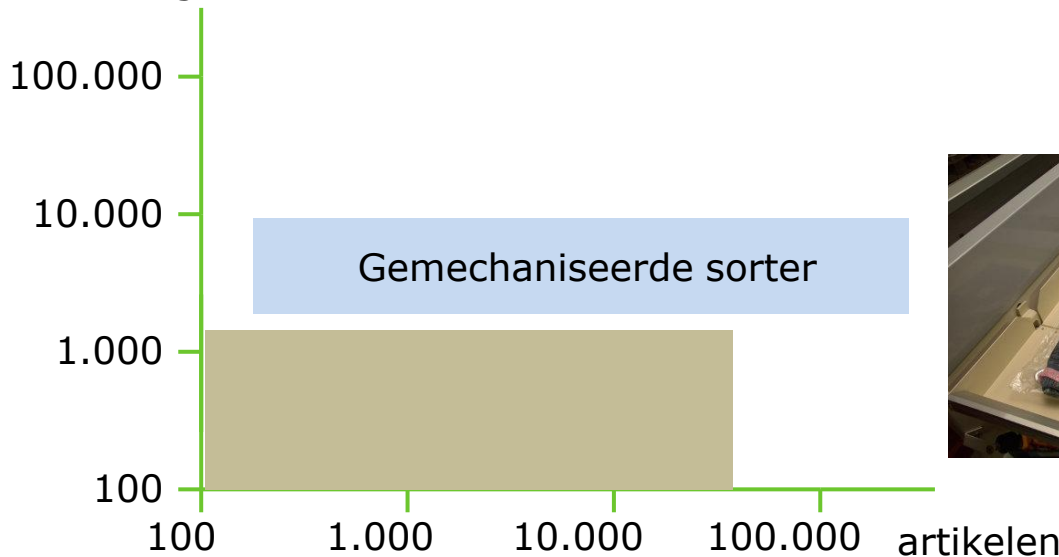

Mini-batch pick

OPLOSSING - PICK PER ORDER

Voordeel:

- goede schaalbaarheid
- veel sorteerrichtingen
- Met AS/RS: batches verkleinen tot enkele seconden

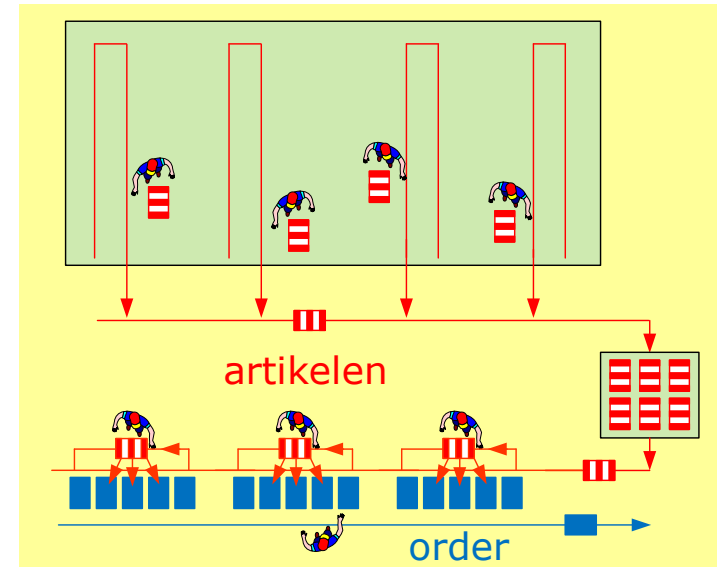
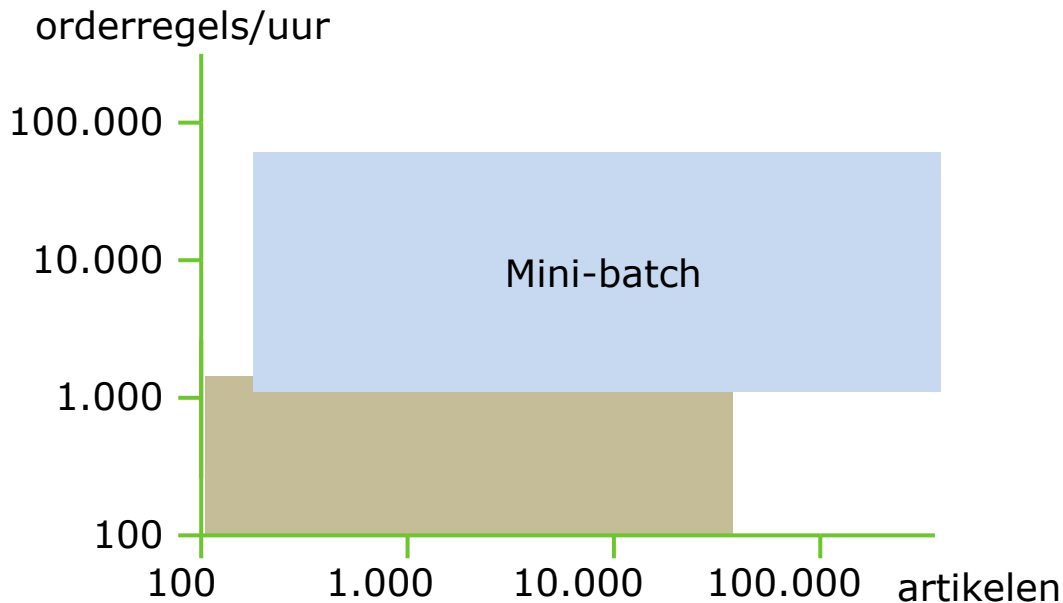

Amazon (D)

VAN DER LANDE
INDUSTRIES



Mini-batch pick

OPLOSSING - PICK PER ORDER

Voordeel:

- goede schaalbaarheid
- grote volumes
- Met AS/RS: batches verkleinen tot enkele minuten

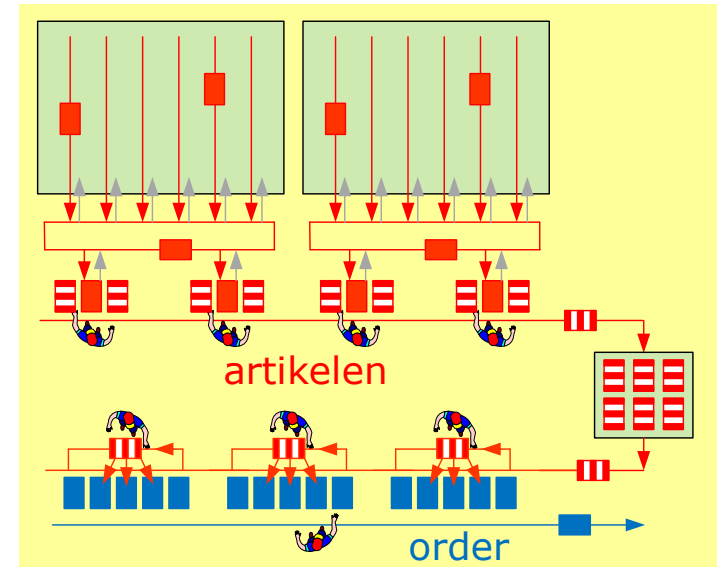
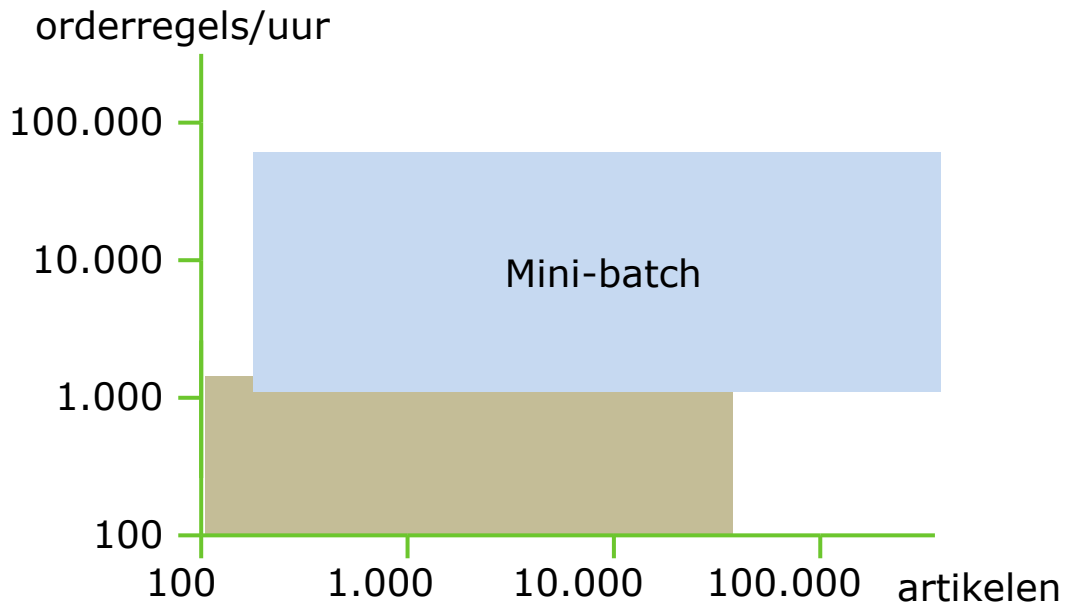

Amazon (D)



Hangbaansysteem met nieuwe toepassing

OPLOSSING - PICK PER ORDER

Voordeel:

- Oneindig veel sorteeruitgangen
- Orderprofiel doet er niet toe

Beperking:

- Hoogte artikel max 150 [mm]
- Gewicht max 5 kg

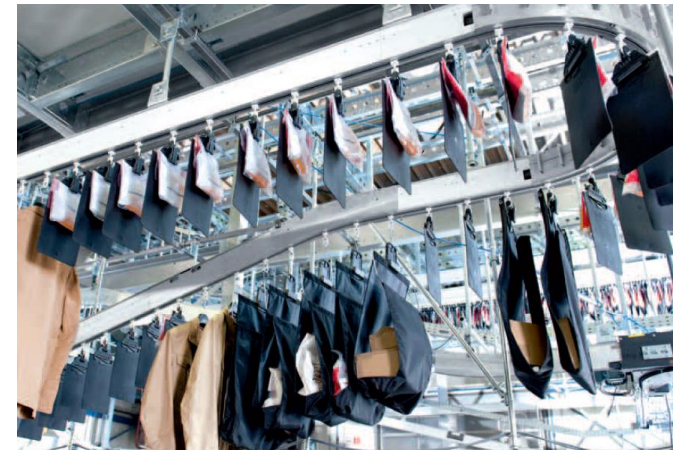
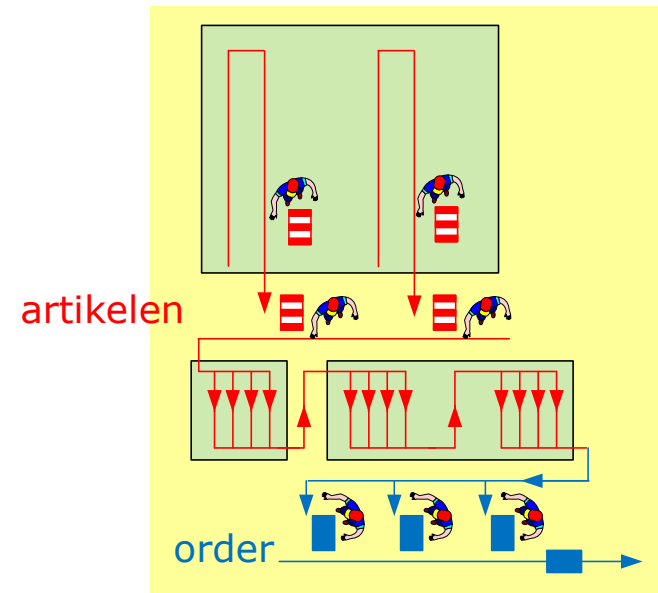
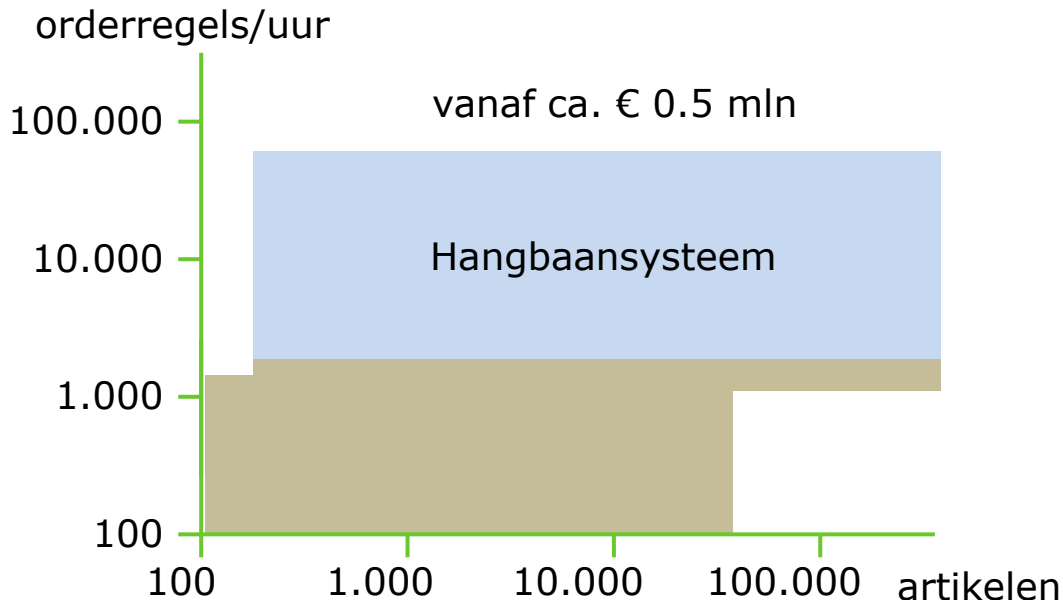

SSI SCHÄFER



Referentieprojecten

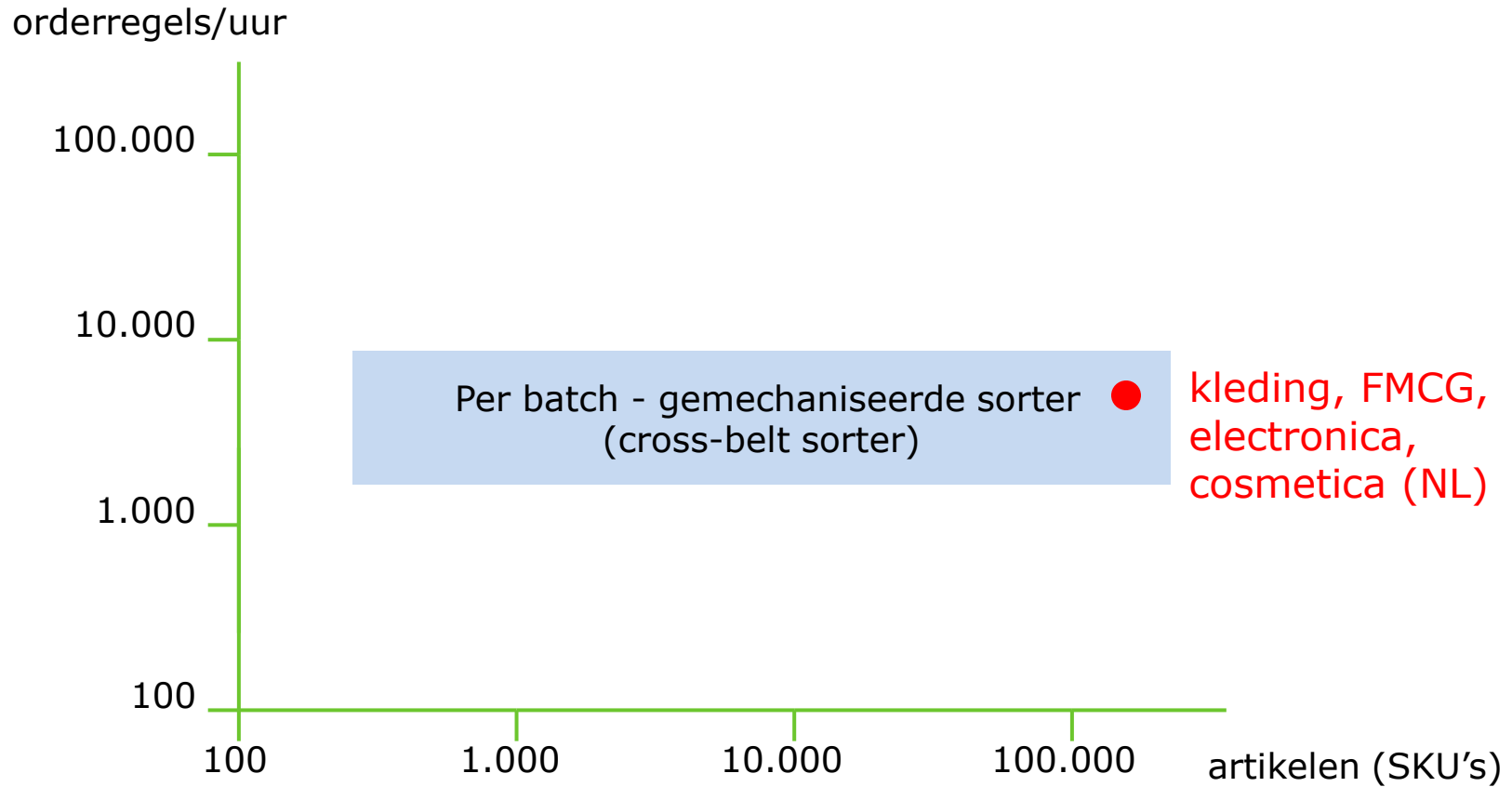

Referentieprojecten

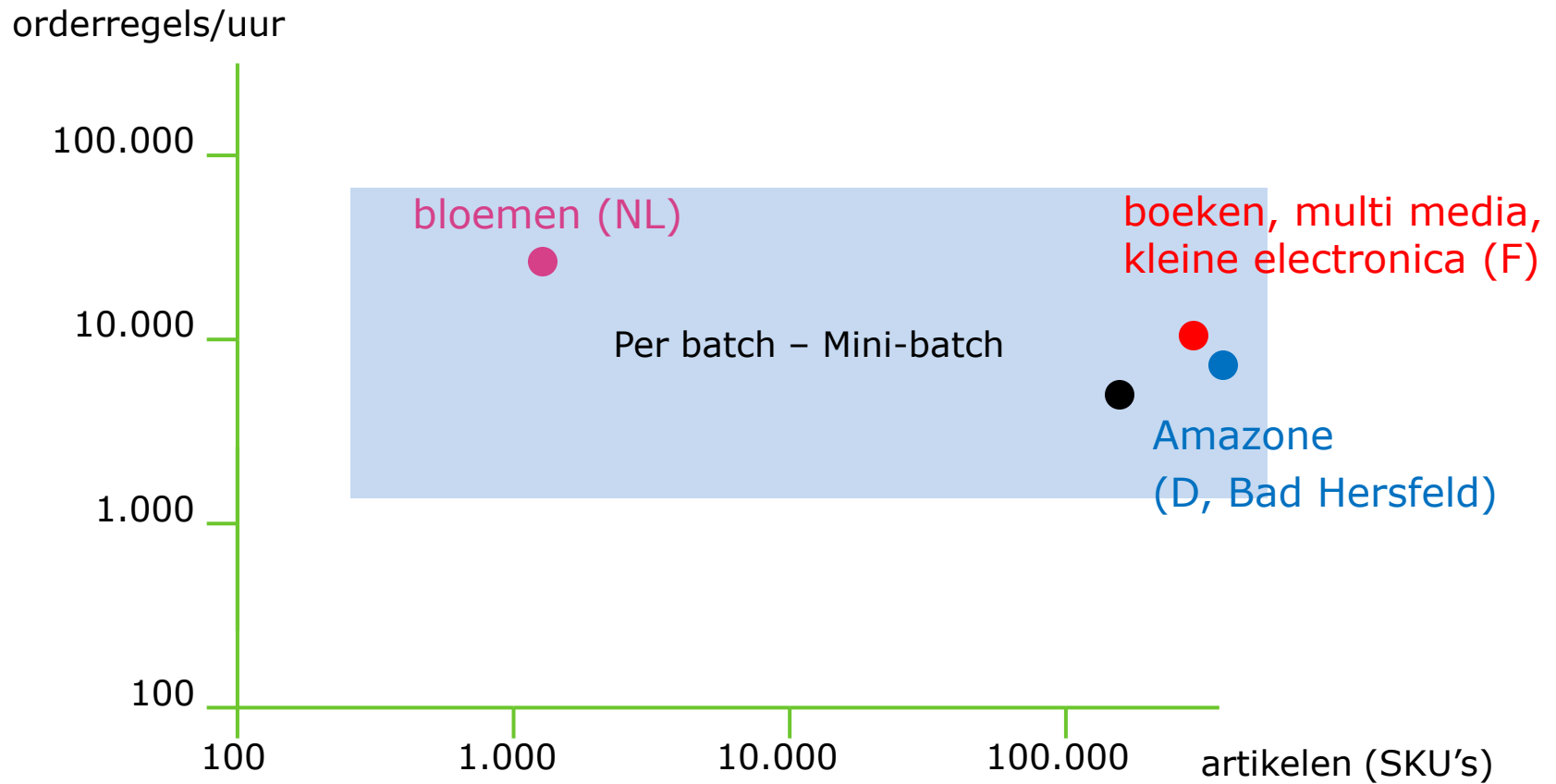

Referentieprojecten

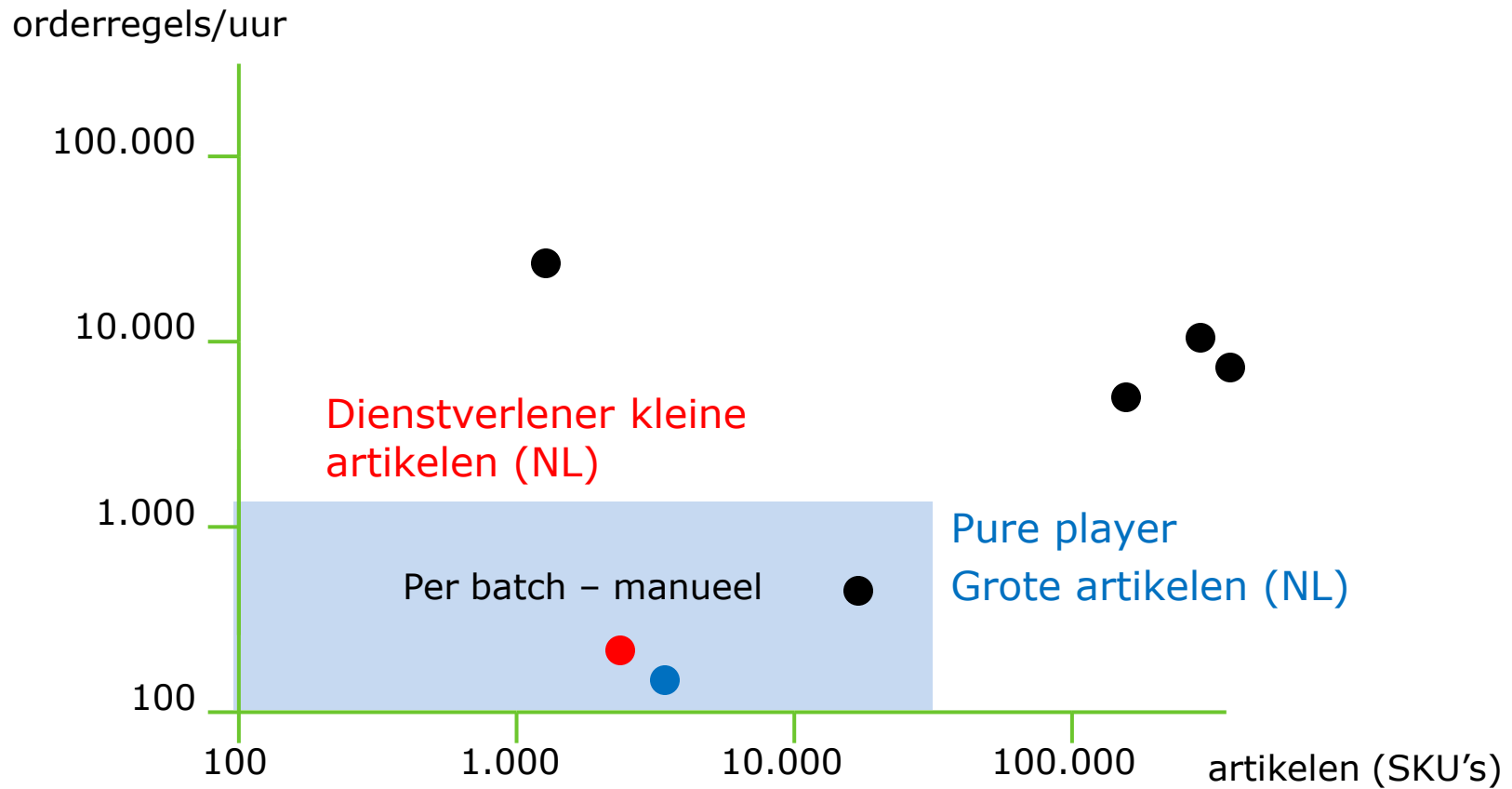

Referentieprojecten

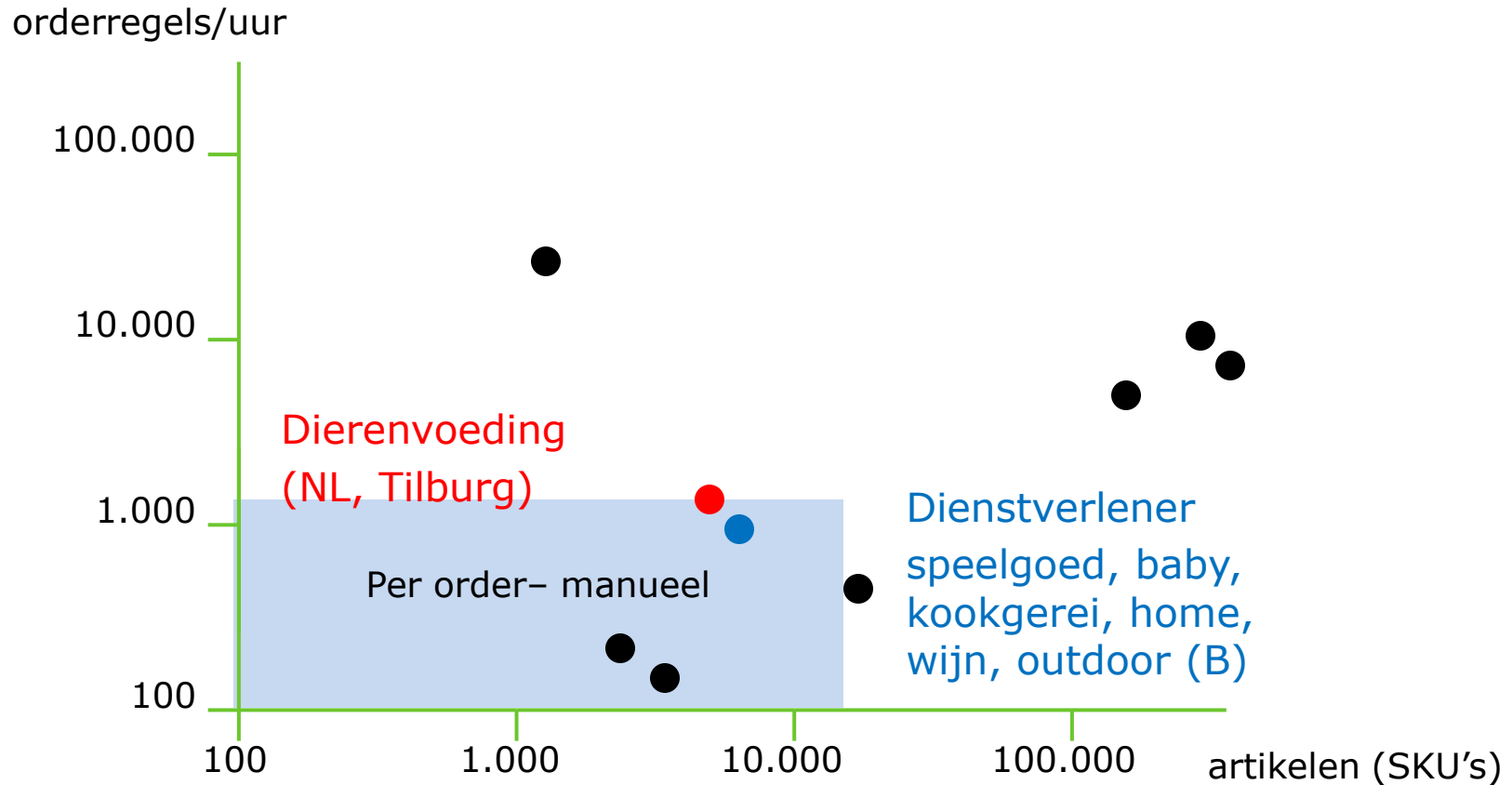

Referentieprojecten

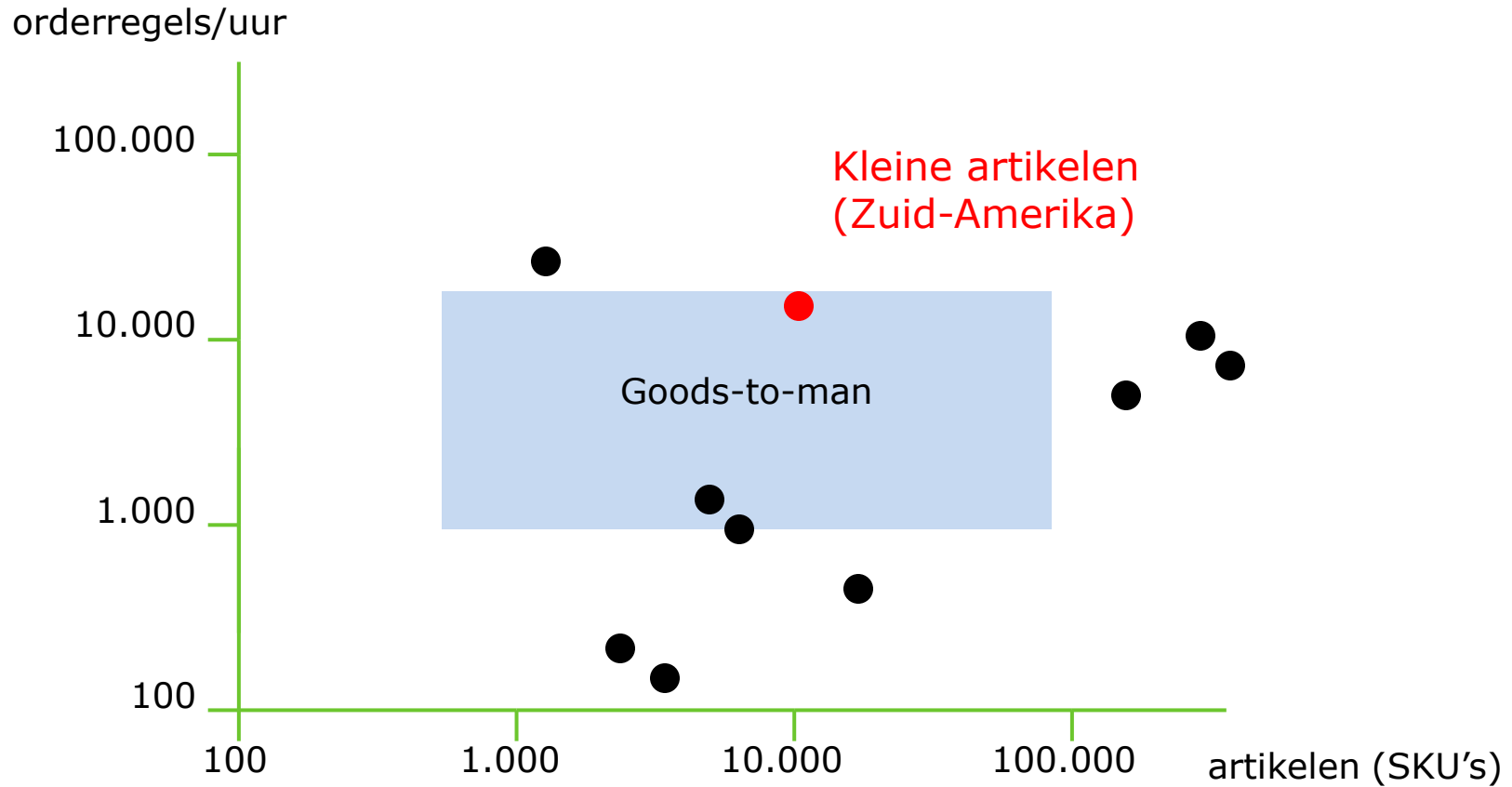



DRIVEN BY KNOWLEDGE

PAUL HAAGH
SENIOR CONSULTANT

T +31 76 5330440
M +31 6 50252788

HAAGH@GROENEWOUT.COM
WWW.GROENEWOUT.COM